



Shenandoah

Instruction Manual



720 Industrial Park Road
Anderson, MO 64831
800-467-6065 FAX 417-845-6069
shenmfg.com
Made in the U.S.A.



FOR YOUR SAFETY

If you smell gas:

1. Open Windows
2. Don't touch electrical switches
3. Extinguish any open flame
4. Immediately call your gas supplier

POUR VOTRE SURETE

Si vous sentez une odeur de gaz:

1. Ouvrez les fenêtres
2. Ne touchez pas aux de commutateurs électriques
3. Eteindre n'importe quelle ouverture flambe
4. Immédiatement appeler votre fournisseur de gaz

FOR YOUR SAFETY

Do not store or use gasoline or other flammable vapors and liquids in the vicinity of this or any other appliance.

POUR VOTRE SURETE

Pas l'essence de magasin ou usage ou les autres vapeurs et les liquides inflammables à proximité de cet ou l'autre appareil.

Note: The original, authoritative version of this manual is the English version produced by CTB, Inc. or any of its subsidiaries or divisions, (hereafter collectively referred to as "CTB"). Subsequent changes to any manual made by any third party have not been reviewed nor authenticated by CTB. Such changes may include, but are not limited to, translation into languages other than English, and additions to or deletions from the original content. CTB disclaims responsibility for any and all damages, injuries, warranty claims and/or any other claims associated with such changes, inasmuch as such changes result in content that is different from the authoritative CTB-published English version of the manual. For current product installation and operation information, please contact the customer service and/or technical service departments of the appropriate CTB subsidiary or division. Should you observe any questionable content in any manual, please notify CTB immediately in writing to: CTB Legal Department, P.O. Box 2000, Milford, IN 46542-2000 USA.



DANGER !

SICKNESS AND/OR DEATH MAY RESULT FROM USE OF THIS HEATER IN AN UNVENTILATED BUILDING OR IN HUMAN LIVING AREAS.

LE RESULTAT DE MAI DE MORT DE ET/OU DE MALADIE DE L'USAGE DE CET APPAREIL DE CHAUFFAGE DANS UN CONSTRUISANT UNVENTILATED OU DANS L'HUMAIN SECTEURS VIVANTES.

EL USO DE ESTA CALENTADORA EN UN UNVENTILATED CONSTRUYENDO O EN HUMANO AREAS PUEDE RESULTAR EN ENFERMEDAD Y/O MUERTE

- | | |
|---|--|
| <p>⚠ Do not use the heater to heat human living areas. The intended use of the heater is to provide warmth for poultry and hog buildings. Adequate ventilation must be provided.</p> | <p>⚠ Ne pas utiliser l'appareil de chauffage pour chauffer humain habiter les secteurs. L'usage voulu de l'appareil de chauffage sera obligé à fournir la chaleur pour les bâtiments de volaille et cochon. La ventilation suffisante doit être fournie.</p> |
| <p>⚠ Use only the type of gas being supplied to the unit as marked on it (Propane or Natural Gas). Do not operate with improper fuel. Ventilation air and combustion air must not be obstructed.</p> | <p>⚠ Utiliser seulement le type de gaz étant fourni à l'unité comme marqué dessus (le Propane ou le Gaz Naturel). Ne pas fonctionner avec le carburant déplacé. L'air de ventilation et l'air de combustion ne doivent pas être encombrés.</p> |
| <p>⚠ Test all pipe and pipe joints for leaks by a suitable means (Example: soap and water solution or a pressure check). Do not operate the heater until this test has been preformed.</p> | <p>⚠ Essayer tous joints de tuyau et tuyau pour les fuites par un moyens convenables (l'Exemple : la solution de savon et eau ou un contrôle de pression). Ne pas fonctionner l'appareil de chauffage jusqu'à ce que ce test a été préformé.</p> |
| <p>⚠ Do not move, handle, repair, or adjust height of the heater while in operation or when still hot. Do not bypass any safety devices.</p> | <p>⚠ Pas le mouvement, la poignée, la réparation, ou ajuster la hauteur de l'appareil de chauffage pendant que dans l'opération ou quand calme chaud. Ne pas sauter d'appareils de sûreté.</p> |
| <p>⚠ Before each use, a visual inspection of the heater is essential to insure safe and satisfactory heating. Replace or repair defective components before operating heater. Failure to do so will void warranty and could result in injury or property damage.</p> | <p>⚠ Avant que chaque usage, une inspection visuelle de l'appareil de chauffage est essentielle pour assurer le chauffage sûr et satisfaisant. Remplacer ou réparer des composants le défectueux avant de fonctionner appareil de chauffage. L'échec pour ainsi faire annulera la garantie et pourrait avoir pour résultat les dommages de blessure ou propriété.</p> |
| <p>⚠ The installation of these appliances is to be in accordance with CAN/CGA-B149.1 and National Fuel Gas Code, ANSI 2223.1/NFPA 54 installation codes for gas burning appliances and equipment and/or local codes.</p> | <p>⚠ L'installation de ces appareils sera obligé à être conformément à CAN/CGA-B149.1 et Code de Gaz de Carburant National, ANSI 2223.1/NFPA 54 codes d'installation pour le gaz appareils ardents et et/ou d'équipement codes locaux.</p> |
| <p>⚠ WARNING: Improper installation, adjustment, alteration, service or maintenance can cause property damage, injury or death. Read the installation, operating and maintenance instructions thoroughly before installing or servicing this equipment.</p> | <p>⚠ L'AVERTISSEMENT : l'installation Déplacée, l'ajustement, le changement, le service ou l'entretien peuvent causer les dommages de propriété, la blessure ou la mort. Lire l'installation, fonctionnant et les instructions d'entretien à fond avant d'installer ou entretenir cet équipement.</p> |

DSI UNITS MUST BE PROPERLY GROUNDED. DO NOT ALTER ELECTRICAL CORD.

LES UNITES DE DSI DOIVENT ETRE CONVENABLEMENT FONDE. Ne PAS CHANGER LA CORDE ELECTRIQUE.

Las UNIDADES de DSI se DEBEN MOLER APROPIADAMENTE. No ALTERE CUERDA ELECTRICA.

Plug in the three-prong power cord to a correctly grounded three-prong electrical outlet.

CONVECTION BROODER - PARTS LIST & ASSEMBLY INSTRUCTIONS

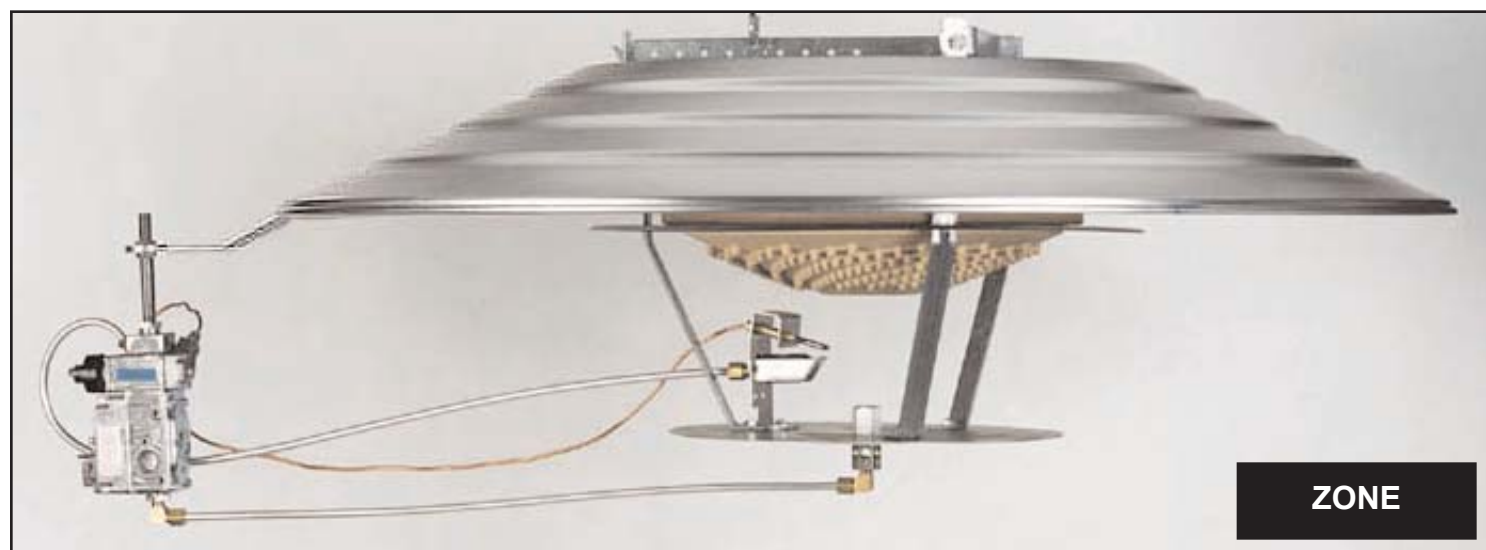
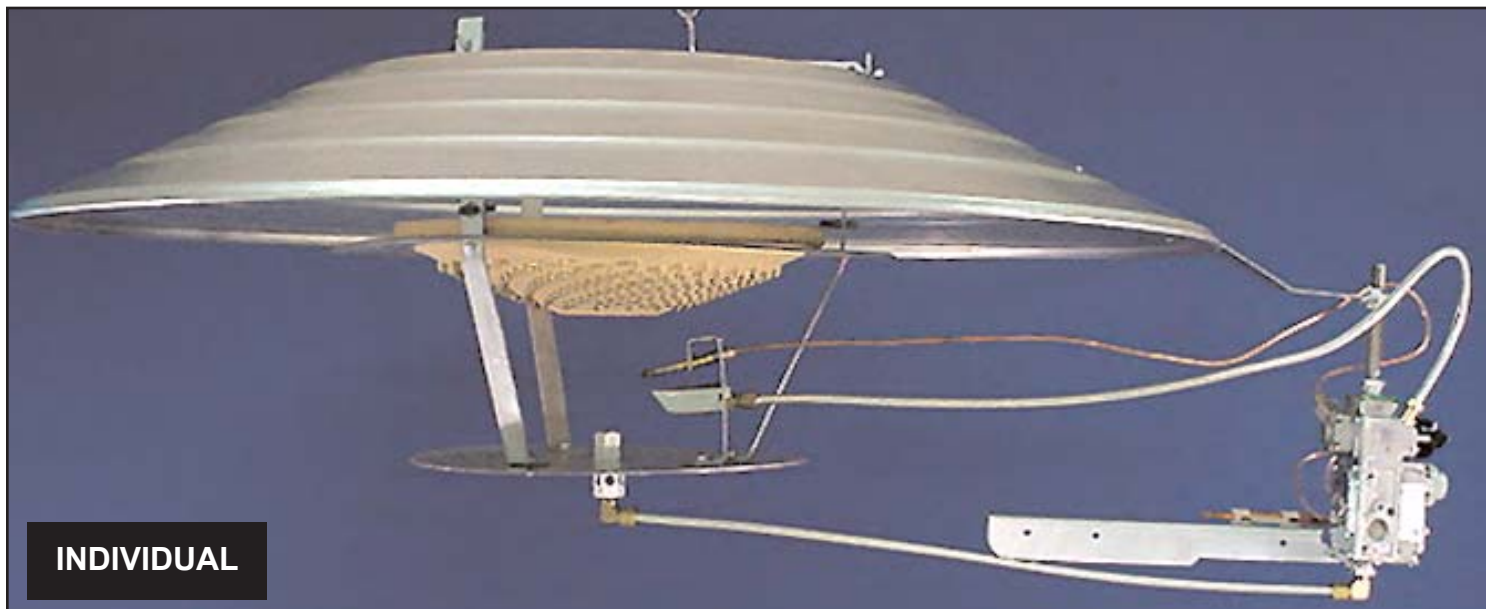

TOOLS REQUIRED FOR ASSEMBLING BROODER:

- Phillips Screwdriver,
- Open End Wrenches (3/8, 5/8, 7/16, 9/16, 1/2, 11/16 & 3/4)
- Nut driver 5/16
- Pliers and an adjustable wrench



16500119 PARTS BAG



16-10335 Washer: 3/8 X 1 1/4 Fen



16-11176 LOCKNUT: HEX STEEL



18003945 Screw 10-24 X 3/8"



18000021 Nut 10-24 Star Kep



11000118 COMP SLEEVE 1/4



11000191 COMP NUT 1/4



21020493
BROODER LEGS
JET HEATERS



16-11152
RADIANT: BRDR FIBER
GB/SB/SJ



18005057
RADIANT TURBO CLAY



21004039
RADIANT RING

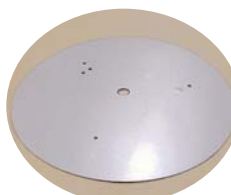

21034039 BURNER PAN
ROCKET JET



16-104093 Brkt: Universal
Brooder Control



11004105 Radiant Clips



11004900 S-Hook Large



21004002
Back "T" Hanger



21014002
Front "T" Hanger



11000187 1/4-20 Nut



11000028 1/4-20 x 5/8 Bolt



11000338 1/4-20 Washer Lock Split



28024042 PILOT BODY
FINISHED



11002205 LP ORIFICE #78
ONE PIECE

11002203 NAT ORIFICE #73
ONE PIECE



21007088 PILOT BRKT SQ PILOT



11000317 Jet Nozzle Threaded

11000315 Jet Air Mixer 31M



21000624 Elbow Brass 1/4MCT X 1/8MPT



11010223
11010218

ORIFICE #52
ORIFICE #43

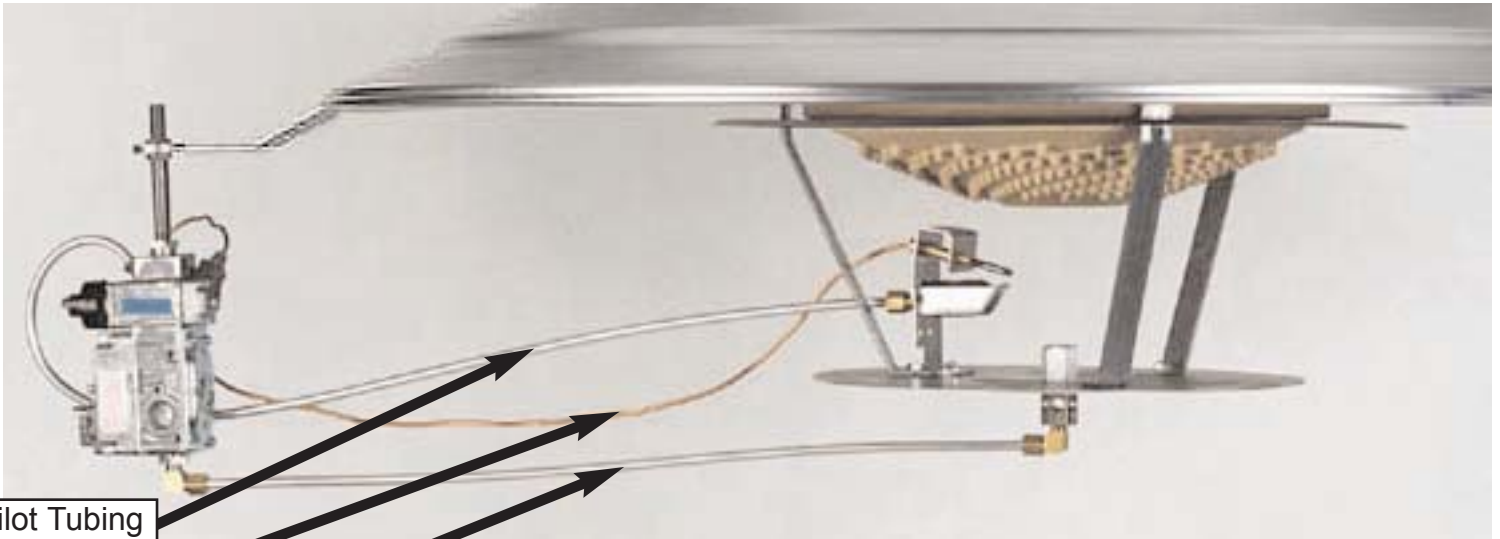

Pilot Tubing

Thermocouple

Burner Tubing



Burner Tubing - 16000001 TUBE ALUM
3/8 X .035 X 20 1/2
Pilot Tubing - 21260326 TUBE ALUM
1/4 X .032 x 32



11000663 Thermocouple: 30"
16-11154 THERMOCOUPLE: 24 IN



11010033 Canopy 34" HDA
11011008 Canopy 34" Galv.



11014053 CANOPY 46 ALUM
11011009 CANOPY 46 GALV

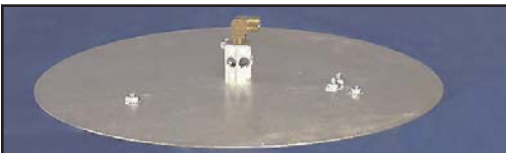

31034039 BURNER PAN 31M LP
31044039 BURNER PAN 31M NAT DOM



31004000 PILOT ASM LP SQ PLT
31014000 PILOT ASM NAT SQ PLT

STEP 1: Set the RADIANT RING with the lip up.



STEP 2: Insert the double bent end of the brooder leg through the slot in the radiant ring down to the bent tabs in the middle of the leg. Be sure that the tab is facing the outside of the radiant ring.



CGA ONLY

STEP 3 : Attach the **PILOT BRACKET** to the top of **BURNER PAN**. The threaded brass fitting on the pilot assembly must be facing the outside of the pan.

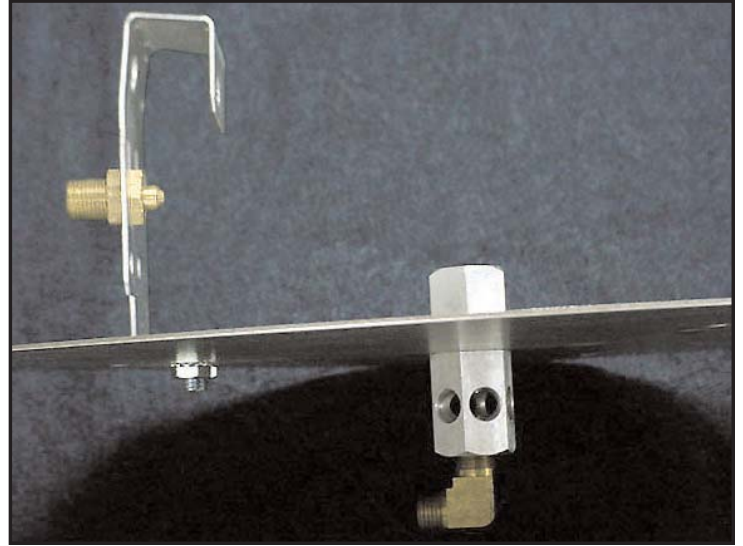
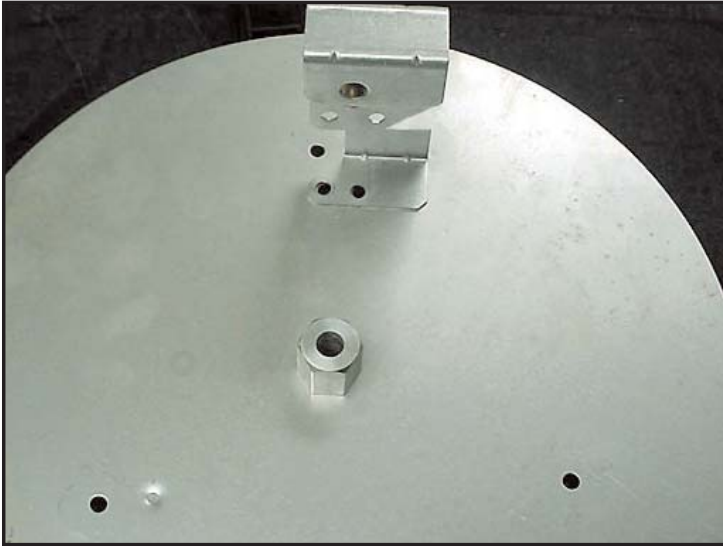

STEP 4 : Turn the burner pan upside down so the pilot bracket is pointed down. Attach the burner pan to the brooder legs.



STEP 5 : Flip the entire assembly over. Install the **CERAMIC RADIANT** with the smooth side up and secure in place with the **RADIANT CLIPS**. Push the radiant clips through the hole in the brooder leg from the outside of the leg to the inside.



STEP 6 : Locate the holes on the outer edge of the **CANOPY**, align these holes with the brass **ELBOW INLET** on the bottom of the burner pan. Place the canopy on the burner assembly by sliding the brooder legs through the slots in the canopy.

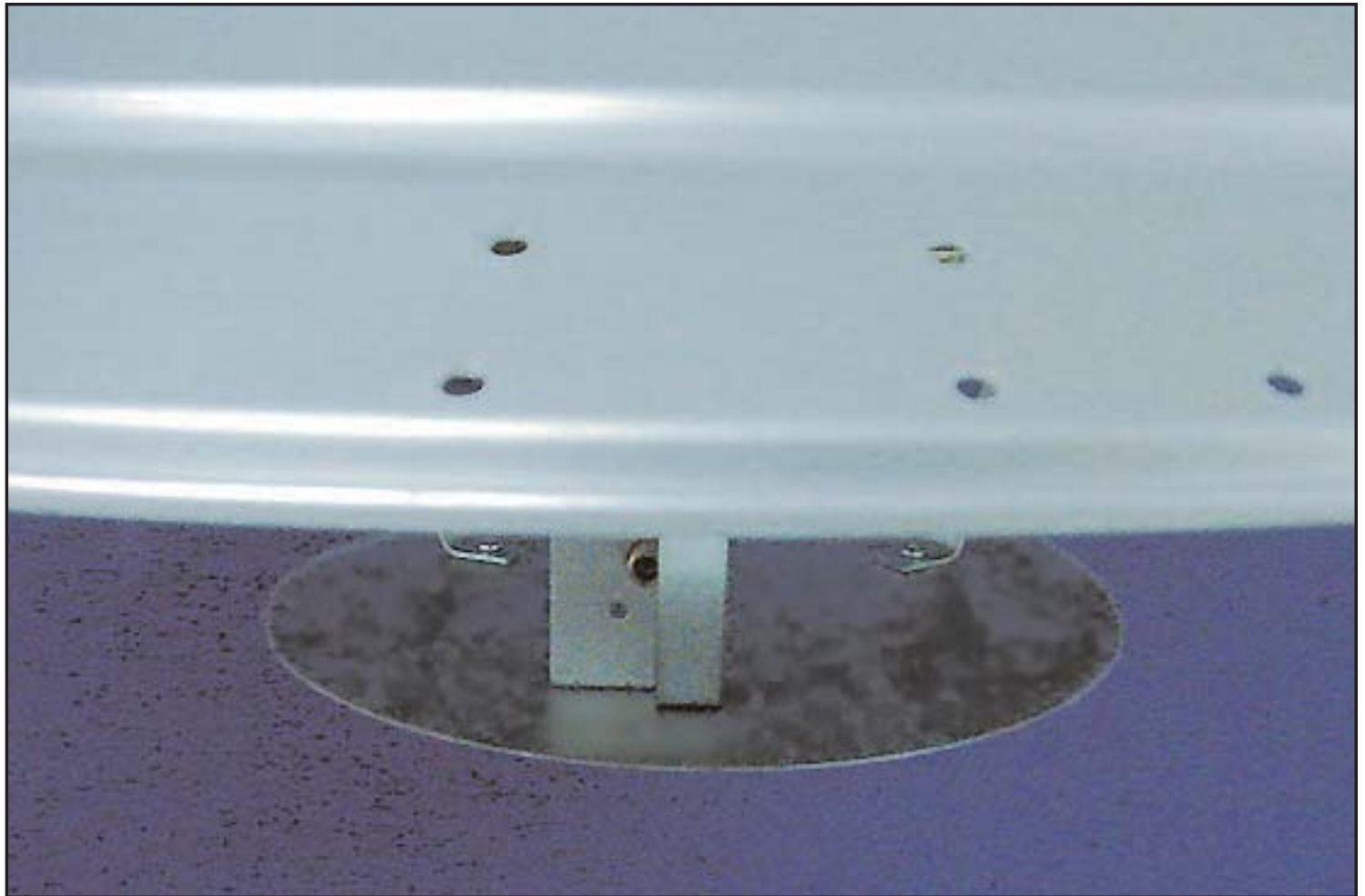

STEP 7 : Insert the slot in the middle of the BACK T-HANGER into the slot in the end of the FRONT T-HANGER

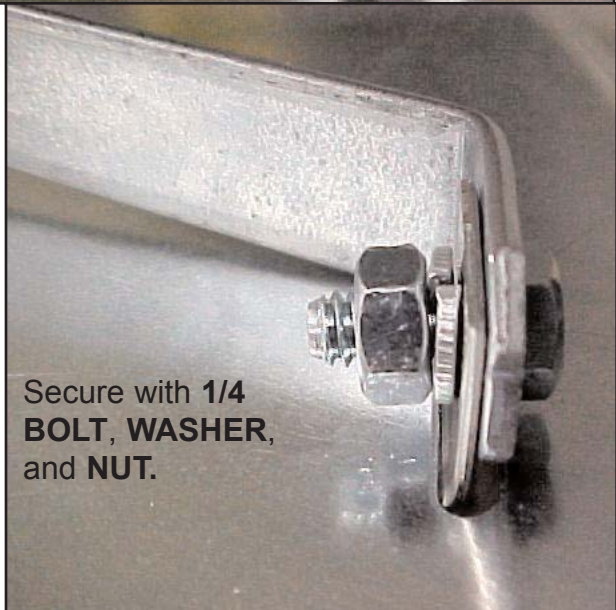
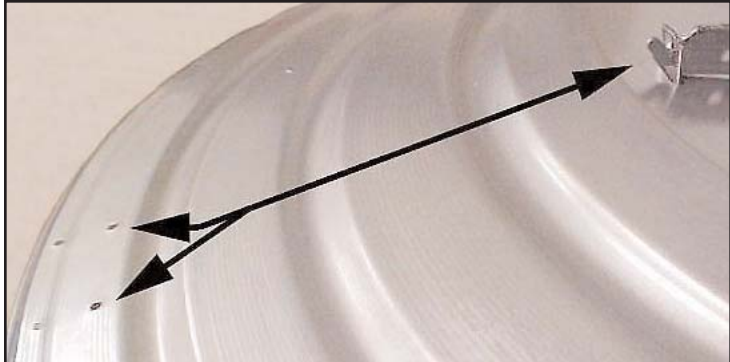
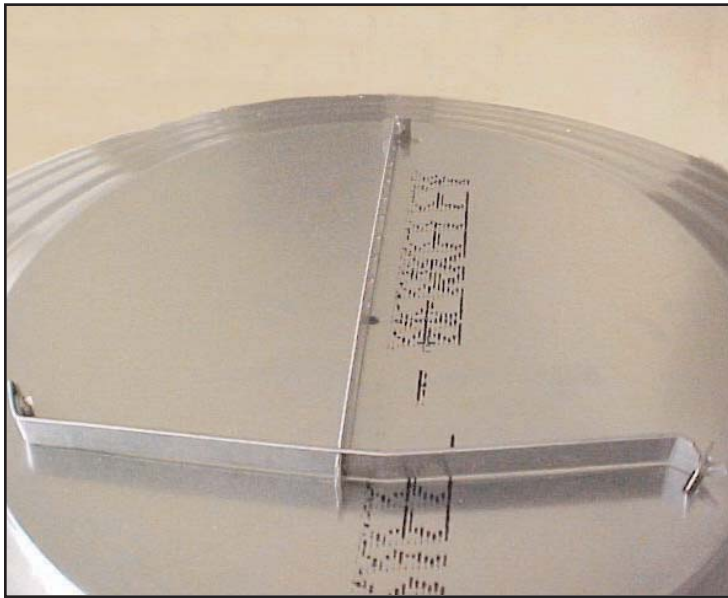
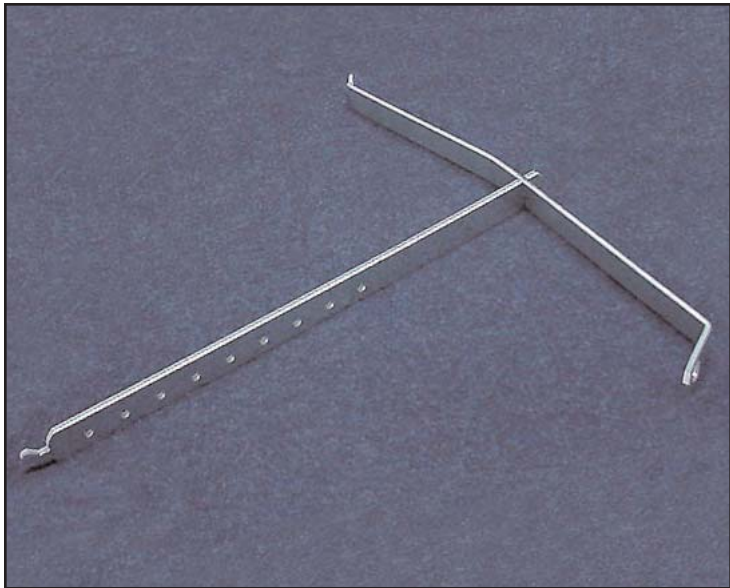
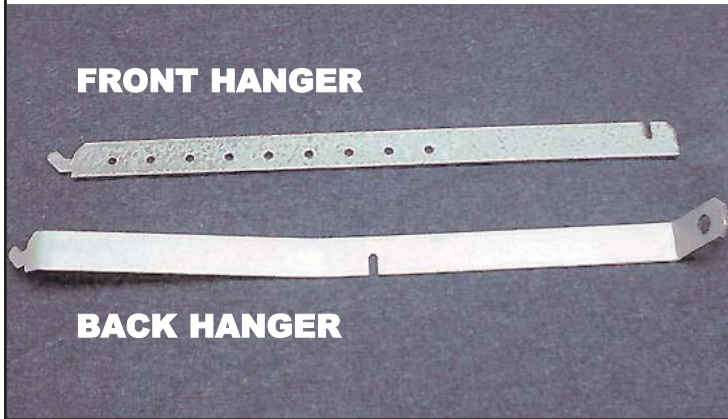

STEP 8 : Attach **BRACKET** to top of **CANOPY** with two **10-24 SCREWS** and **NUTS**



STEP 9 : Place one 3/8 x 11/4 **WASHER** on the inlet pipe on top of the lock nut. Insert the pipe through the hole in the rounded end of the **CONTROL BRACKET**. Secure with one washer and lock nut.

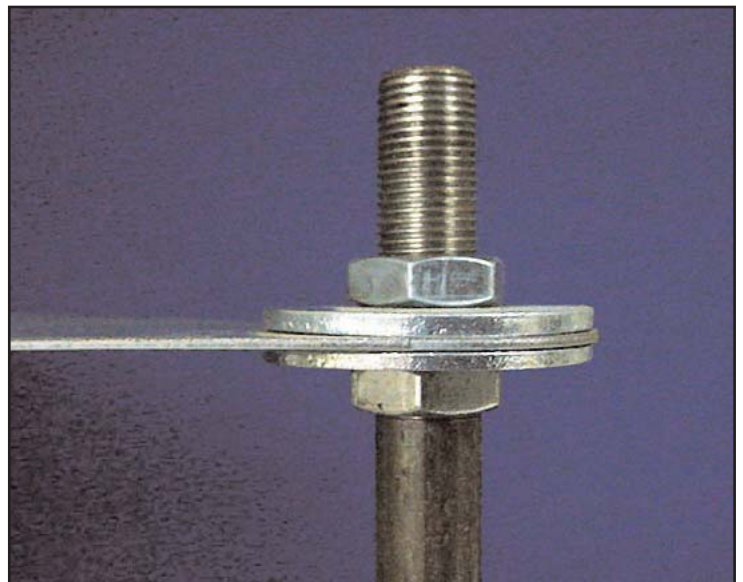

FOR LARGE CANOPY:

Place one **WASHER** on the inlet pipe of the valve on top of the the nut. Insert the pipe into the larger hole in the canopy from the underside. Secure with a **WASHER** and **NUT** on the **top** side of the canopy.

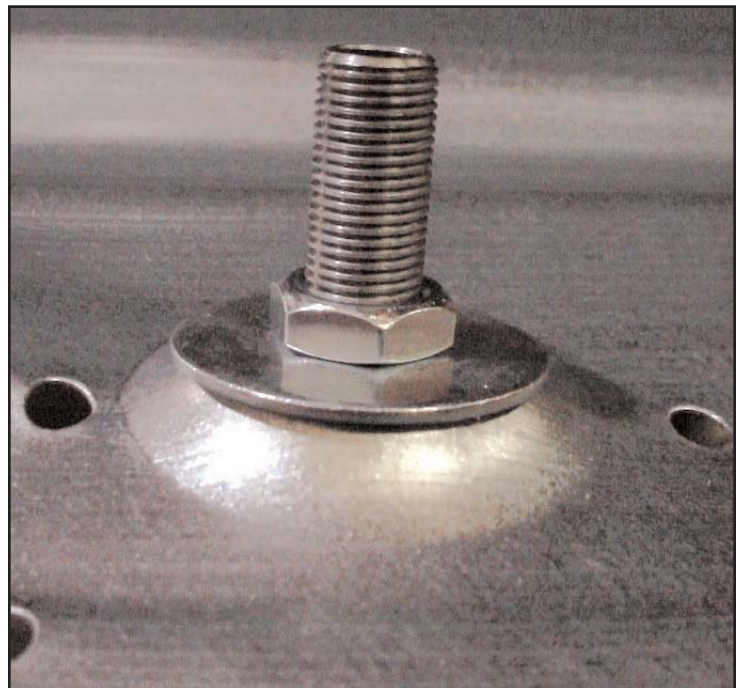

STEP 10 : Attach **BURNER TUBING** to brass fitting on the underside of the burner pan and then to the fitting on the bottom of the control valve using two wrenches to prevent damaging tubing.

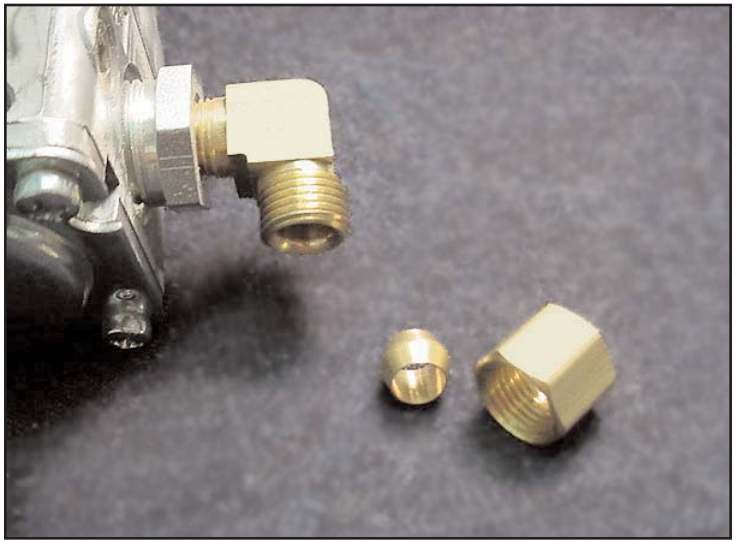
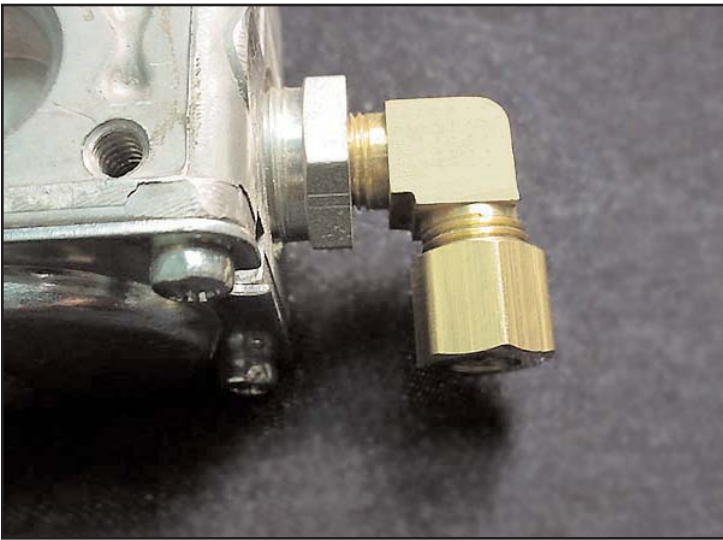
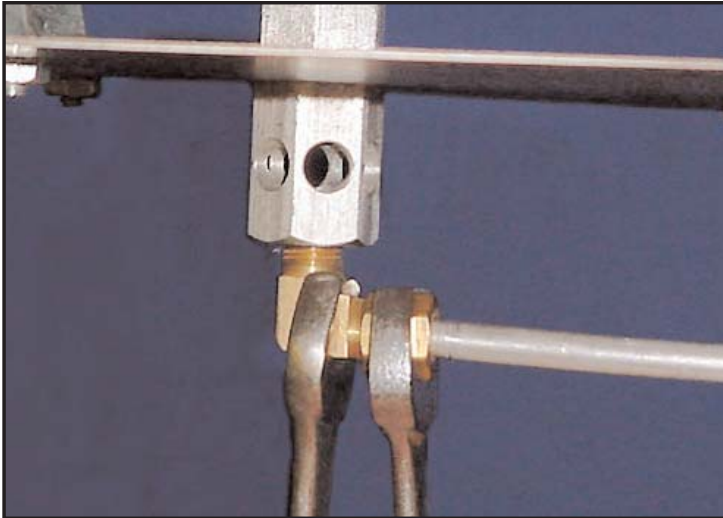

STEP 11 : Connect the remain 1/4" aluminum tubing to the brass fitting on the PILOT ASSEMBLY. Hand form the tubing to connect to the brass fitting on top of the control valve.

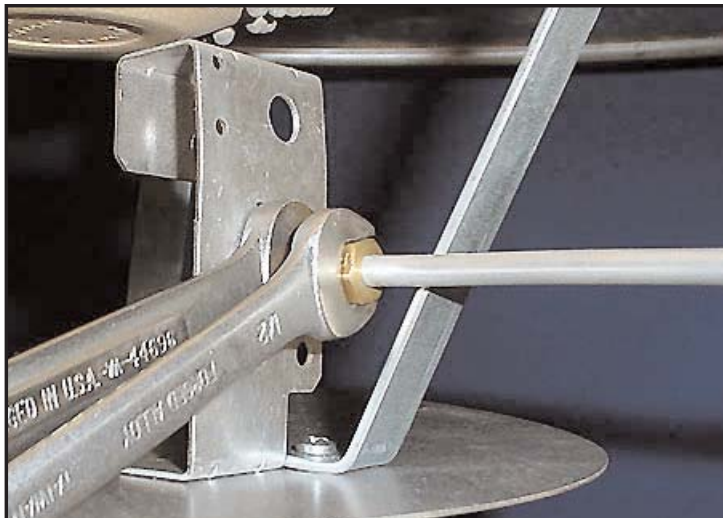

STEP 12 : Insert the rod end of the **THERMOCOUPLE** into the hole above the 1/4" aluminum tubing on the **PILOT ASSEMBLY**.

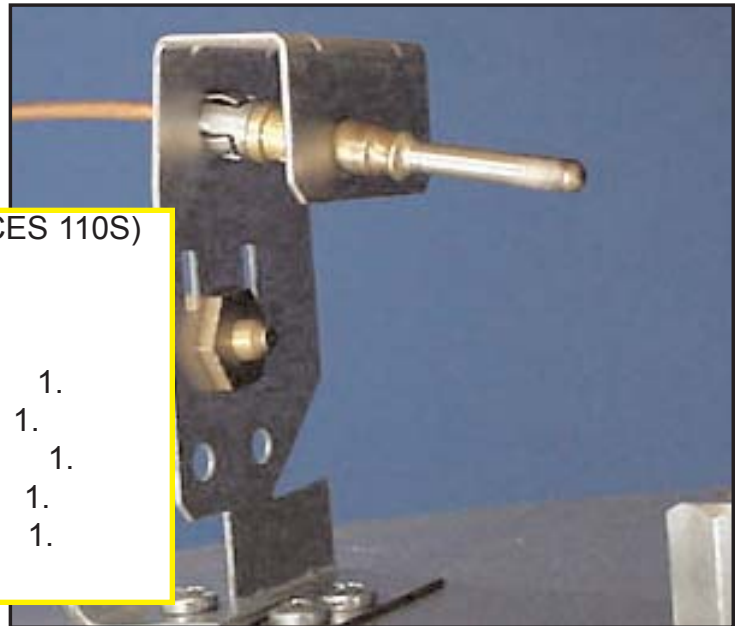

16000106 VALVE 7000 SLC (REPLACES 110S)
REPLACEMENT FOR 110S (SNAP)

16500164	CTRL ASM: LP & NAT CONV	1.
16500165	CTRL ASM: LP & NAT L/INF	1.
16500164P	CTRL ASM: LP & NAT CONV	1.
16500165P	CTRL ASM: LP & NAT L/INF	1.
16500172	RETRO KIT 110'S TO 7000SL	1.

STEP 13 : Attach **THERMOCOUPLE** to

51001000	RKT JET 31M 110'S LP CERM
51001100	RKT JET 31M 110'S NAT CER
51001550	RKT JET 31M 110'S EXP CER
51002000	RKT JET 31M IND ZONE LP C
51002100	RKT JET 31M IND ZONE NAT
51002550	RKT JET 31M IND ZONE EXP
51003000	RKT JET 31M IND MODUL LP
51003100	RKT JET 31M IND MODUL NAT
51003550	RKT JET 31M IND MODUL EXP

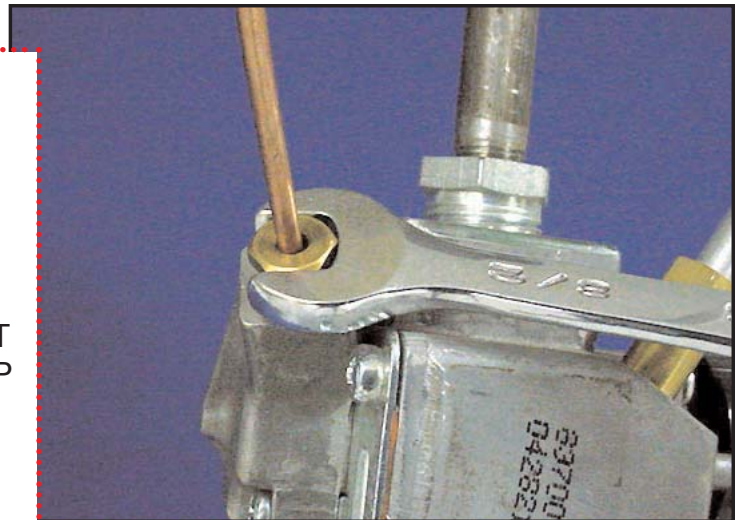

STEP 14 : Slide the **SQUARE PILOT BODY** into the slots on the Pilot Assembly.

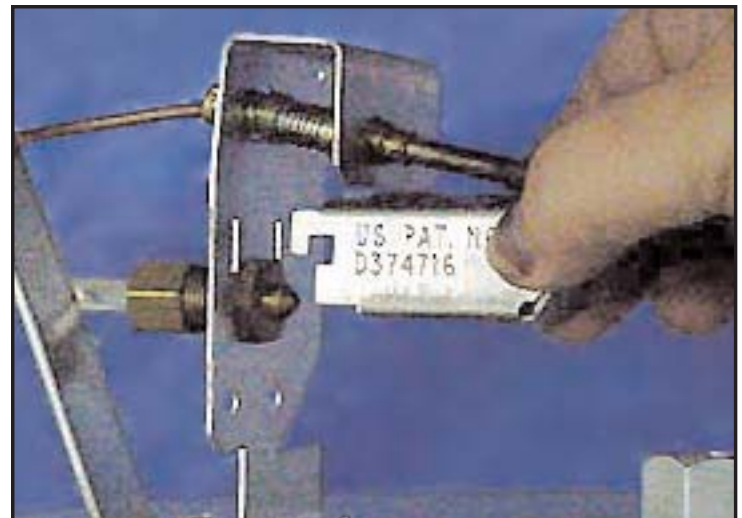

STEP 15 : Suspend the brooder: To level the heater, simply support the heater underneath and then move the S-hook forward or backward. After it is level clamp both ends of the s-hook shut. The brooder should hang with the control assembly tilted slightly downward. Normally the brooder is attached to a winch cable used for raising and lowering. In addition, we strongly recommend that a safety cable or chain be attached to the brooder to prevent the brooder from falling to the litter if the winching cable should happen to break.

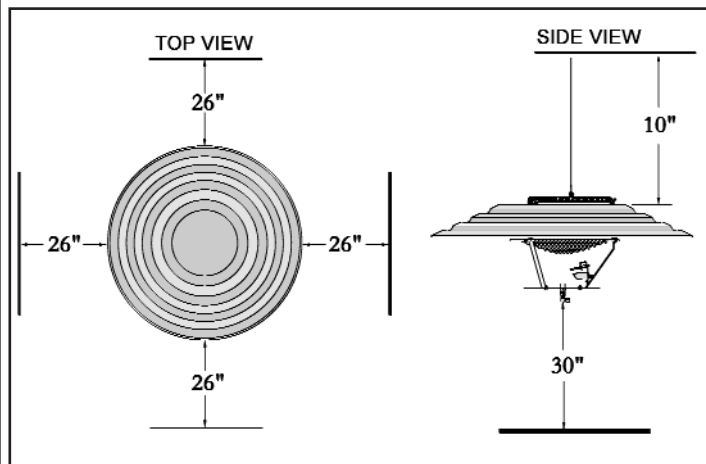
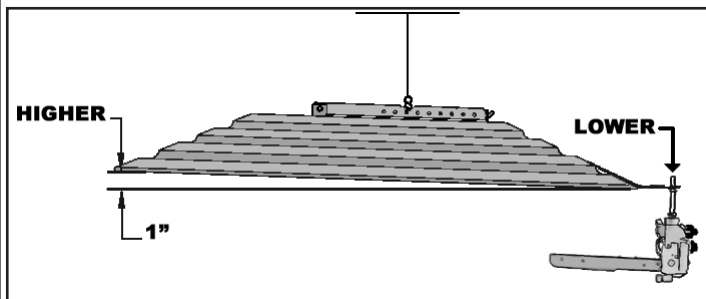

GENERAL INFORMATION

The heater must be located so there is a minimum clearance of 10" above the heater and 26" from the side. Any combustible material must not be adjacent to the heater.

The heater should be hung with a min. of 30" from bottom of the heater to the floor.

Be sure to comply with all local, state, and federal gas codes for your area.

STEP 16 : Attach the hose (use only a CGA approved gas hose assembly in accordance with CAN/CGA - B149.1 and B149.2) from the gas supply to the pipe on the control using hose clamps (not provided). Check all connections for leaks before lighting brooder. - See lighting instructions

STEP 17 : GAS PRESSURE - should be CHECKED AND ADJUSTED to recommended settings.

LP GAS:

FIRST - go to the furthest stove from the regulator and connect the pressure gauge to the Press Tap on the gas valve. Light only the stove you are testing or if you have a zone system light all the stoves in the zone. Set the pressure at a maximum of 11 ¼" WC.

SECOND - light all stoves in the house and check the pressure again. The pressure should not drop below 10 ½" WC. If the pressure does fall below 10 ½" WC, then the gas distribution system is inadequately designed. The problem may be a regulator, pipe sizing, etc.

NATURAL GAS

Use same procedure as LP gas above, except the pressure should not exceed 7 ¼" W.C. with only one stove or zone operating. The pressure should not drop below 6 ½" W.C. with all stoves running.

INDIVIDUAL THERMOSTAT

(STANDARD)

16500164

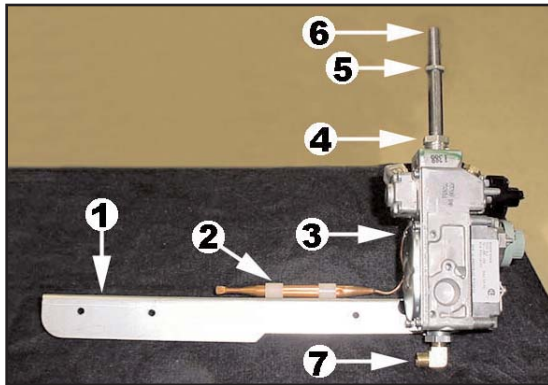

1	SHIELD: UNIVERSAL BRDR	16-104219
2	CLAMP WIRE NYLON	11000033
3	VALVE 7000 SLC	16000106
4	BUSHING: GALV STDHEX 3/8X1/8	16-11194
5	LOCKNUT: HEX STEEL	16-11176
6	NIPPLE: GALV 1/8 X 3-1/2 SPEC	16000000
7	ELBOW BRASS 1/4M COMP	11000624
	RIVET: NYLON PUSH-IN RIV	16000036

16-85050130
16-85050540

BRNR TUBE: ALUM 1/4 X .032 X 21
PLT TUBE: ALUM 1/4 X .032 X 28 1/2

INDIVIDUAL THERMOSTAT

MODULATING

16-104438

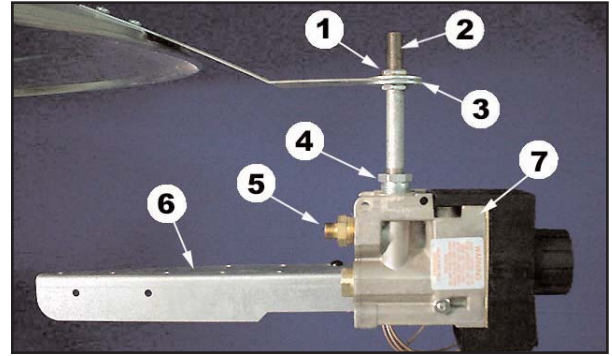

1	LOCKNUT: HEX STEEL	16-11176
2	NIPPLE: GALV 1/8 X 3-1/2 SPEC	16000000
3	WASHER: 3/8 X 11/4 FENDER	16-10335
4	BUSHING: GALV STDHEX 3/8X1/8	16-11194
5	CONN 3/8MPT X 1/4MCT	18000037
6	SHIELD: UNIVERSAL BRDR	16-104219
7	CTRL: SIT EUROSIT VALV	16-10436350

16-85050130
16-85050120

BRNR TUBE: ALUM 1/4 X .032 X 21
PLT TUBE: ALUM 1/4 X .032 X 20 1/4

24 VOLT ZONE

16-104440

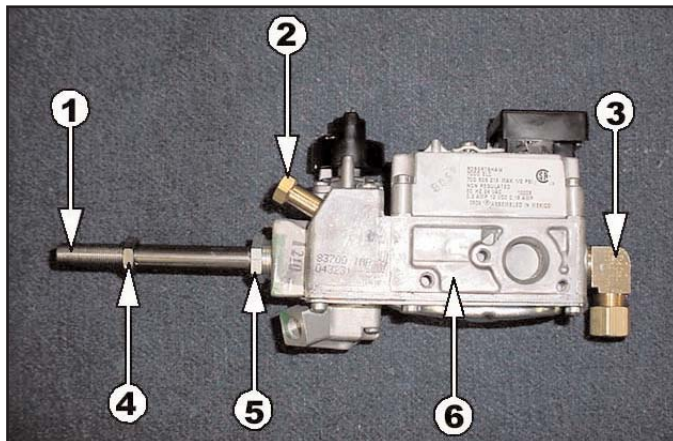

1	NIPPLE: GALV 1/8 X 3-1/2 SPEC	16000000
2	Comp Nut & Sleeve 1/4"	11003995
3	ELBOW BRASS 1/4M COMP	11000624
4	LOCKNUT: HEX STEEL	16-11176
5	BUSHING: GALV STDHEX 3/8X1/8	16-11194
6	VALVE 7000 ELC (BARE)	11004081

16-85050130
16-85050540

BRNR TUBE: ALUM 1/4 X .032 X 21
PLT TUBE: ALUM 1/4 X .032 X 28 1/2

TWO PIPE SUPPLY

31005223

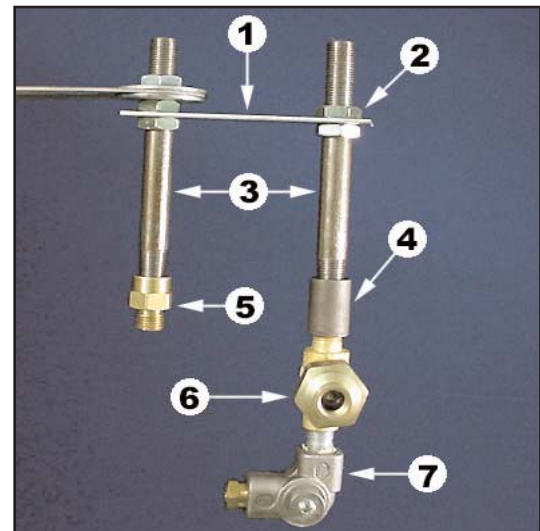

1	BRKT TWO PIPE SUPPLY	21007000
2	LOCKNUT: HEX STEEL	16-11176
3	NIPPLE: GALV 1/8 X 3-1/2 SPEC	16000000
4	COUPLING 1/8" NPT BLK	11001506
5	GRAY ELBOW GAS VALVE	11000331
6	VALVE S.I.T SSO	11005223
7	CONN STRT 1/4 X 1/8	11003986

16000002

TUBE ALUM 1/4 X .032 X 24 1/2

BROODER LIGHTING INSTRUCTIONS

- 1. NEW INSTALLATIONS** - test pipe system for leaks, purge all gas lines of dirt and moisture before connecting brooders. Turn ALL gas cocks to each brooder to the "closed" position. Open tank (LP) or meter valve (Nat.).

GAS PRESSURE - This brooder/heater is designed for 11 inches WC (Water Column) for LP Gas and 7 inches WC for Natural Gas. Conversion from one gas to another requires that both pilot and burner orifices be changed!!

- 2. LIGHTING PILOT:**

INDIVIDUAL & 24 VOLT ZONE CONTROLS - Turn thermostat to lowest setting. Turn the gas cock on the gas supply line to the "OPEN" position. Turn the "on-off" knob on the control valve to the "PILOT" position. Depress reset button and light pilot. Continue to hold down reset button 30 to 45 seconds or until pilot continues to burn when button is released.

MANIFOLD ZONE CONTROL - Turn Zone thermostat to lowest setting. Turn gas supply cock to the "OPEN" position. Depress button on the Safety Shut Off Valve and light pilot; continue to hold 30-45 seconds to activate the Safety Valve, this will enable you to light the Main Burner later.

NOTE: The thermocouple is installed directly in the pilot flame. The top ½ inch of the thermocouple tip gets cherry red. Normal output from this thermocouple is 15-20 millivolts. When installing brooders in a heavy draft area, be sure that the flame is blown toward the thermocouple tip.

- 3. LIGHTING MAIN BURNER** - After pilot is burning, turn the control knob to the "ON" position. NEXT: .

- A. INDIVIDUAL CONTROL** - When ready to ignite main burner, rotate the thermostat knob counterclockwise until main burner lights. To check burner for proper ignition, cycle the thermostat up and down several times, the main burner should light instantly. Set thermostat at desired heat setting.
- B. 24 VOLT ZONE CONTROL** - When ready to ignite main burners, turn the control knob to higher temperature setting until the main burners on the brooders within the Zone light. Cycle the zone thermostat up and down several times, the main burners should light instantly.

Set thermostat at desired heat setting. If main burner does not ignite, check wiring connections.

- C. MANIFOLD ZONE CONTROL** - When ready to ignite main burners, turn each gas cock to the main burner to the "OPEN" position.

NOTE: If temperature in the house is below lowest setting on the zone thermostat the main burner may light). After all gas cocks are in the "OPEN" position rotate zone thermostat to higher temperature setting until all Main Burners within the zone light. Set to desired heat setting.

- 4. BETWEEN BROODS** - Turn pilot "ON/OFF" knob to the "OFF" POSITION. Then, turn gas off at Tank or Meter if desired. This will facilitate start up for the next flock.

WIRING INSTRUCTIONS FOR 24 VOLT ZONE BROODERS/HEATERS

1. Mount "Auto-Switch-Over" (A.S.O.) Power supply in convenient location near electrical panel and WITHIN 3 FEET OF OUTLET. Outlet should be separately fused -- 15 AMP.
2. Mount junction box over each thermostat location selected.
3. Run 14-2 romex from connections on A.S.O. to nearest junction box and continue on to other junction boxes (if used).
4. Run 14-2 romex over each line of brooders to be hooked up to Zone Control. Line should be run adjacent the gas line. If more than one thermostat (zones) is to be used -- black wire should be cut between zones.
5. Cut outer insulation ONLY on romex over each brooder to expose black and white wires. DO NOT CUT OR STRIP WIRES. Bare ground wire is not used.
6. Using "T" tap connectors connect wire from brooder valve (24V) to romex -- white to white; black to black. Note -- cut off excess wire from valve. Tape wire to gas hose and romex to make a neat installation.
7. Connect together in junction box using wire nuts
 - a. Black from feed (A.S.O.)
Black to next junction box (if used)
Black from thermostat
 - b. White from feed (A.S.O.)
White to next junction box (if used)
White from line over brooders
 - c. White from thermostat
to black from line over brooders
8. Light brooder in usual manner and set ZONE thermostat for desired temperature.
9. Check for any voltage drops to brooder.

MAINTENANCE PROGRAM

- ◆ Clean brooder after each flock.
 - ☑ Inspect for any orifice blockage caused by spider webs in the pilot or burner assemblies.
 - ☑  **DANGER!** Never spray penetrating oil (WD-40) on the control valve. This will cause the loss of high temperature valve grease and cause the valve to leak.
 - ☑ Clean dust and dirt from pilot and burner ports with compressed air. If an air compressor is not available turn the brooder to a vertical position and tap on the

side of the pilot & burner brackets with a screwdriver, pliers, or any other suitable object, to knock the dust from the unit.

- ☑ If houses are washed down, care should be taken to prevent moisture from accumulating on control valve, pilot, fiber radiant & burner assemblies. After wash downs we recommend that you light the brooders to dry up any excess moisture.
- ☑ Avoid getting radiant wet, damp fiber radiants distort when exposed to heat.
- ☑ Clean air intakes with a small brush
- ☑ Extreme care must be taken not to enlarge or distort the pilot and burner orifices.
- ◆ Special burner and pilot orifice cleaning kits, which includes the correct size orifice cleaning gauges and brushes, are available for purchase at your local dealer.
- ◆ If brooder is disconnected from the gas line, use tape to seal the open connections. This will keep moisture, dust, and insects out and prevent future problems.

SAFETY PRECAUTIONS

1. Do not use the brooder/heater to heat human living areas.
2. The intended use of the brooder is to provide heating for poultry and hog buildings. Adequate ventilation must be provided.
3. The installation of the brooder must comply with all applicable state, local, and/or national codes in accordance with CAN/CGA - B149.1 or .2 installation codes.
4. Use only the type of gas being supplied to the unit as marked on it (Propane or Natural Gas). Do not operate with improper fuel.
5. Do not expose brooder to rain, snow, sleet, or water. The brooder/heater is designed for indoor use only.
6. Ventilation air and combustion air must not be obstructed.
7. Do not operate the brooder/heater in the presence of combustible vapors, liquids, or gases. Failure to heed this warning could result in an explosion and/or fire.
8. Test all pipe and pipe joints for leaks by a suitable means (Example: soap and water solution or a pressure check). Do not operate the brooder until this test has been preformed.
9. Do not move, handle, repair, or adjust height of the brooder while in operation or when still hot.
10. Do not bypass any safety devices.
11. Before each use, a visual inspection of the brooder/heater is essential to insure safe and satisfactory heating. Replace or repair defective components before operating brooder/heater. Failure to do so will void

SPECIFICATIONS

Capacity

31,000 BTU/h
7.8105 Kcal

Gas Pressure Requirements

Liquid Propane (LP)	11" WC or 6.35 oz. or 27.5 mbar
Natural Gas	7" WC or 4.00 oz. or 17.5 mbar

Gas Consumption 31,000 BTU

Liquid Propane (LP)	.34 gph / 1.29 L/hour
Natural Gas	29.25 cfh / .83 m3/hour

Brooder Dimensions

Width

small canopy 34" / 86.36 cm
large canopy 46" / 116.84 cm

Height 20 1/2" / 52.07 cm

*Weight (Alum., 34" Canopy) 17 lbs. / 7.71 kilograms

Operation Guidelines for Brooding Area

Height (edge of canopy)	36" / 91.4 cm
Space between brooders / side	10-20 ft. / 3-6.1 m
Square feet per brooder	250-600 sq. ft. / 23.2-55.7 sq. m

Minimum clearance to combustibles

Side 36" / 91.4 cm
Top 14" / 35.6 cm
Below 24" / 61 cm

*Will depend on model type.

WARRANTY

Agile Mfg., Inc., ("Agile"), warrants each new SHENANDOAH® product manufactured by it to be free from defects in material or workmanship for one (1) year from and after the date of initial installation by or for the original purchaser. If such a defect is found by the Manufacturer to exist within the one-year period, the Manufacturer will, at its option, (a) repair or replace such product free of charge, F.O.B. the factory of manufacture, or (b) refund to the original purchaser the original purchase price, in lieu of such repair or replacement. Labor costs associated with the replacement or repair of the product are not covered by the Manufacturer. The Manufacturer shall not be responsible for the costs of removal or reinstallation of products and shall not be responsible for transportation costs. The purchaser must first contact the seller to resolve product issues covered under this Warranty. If the purchaser is unable to resolve warranty claims directly with the seller, the purchaser should contact the manufacturer as the address listed below.

Conditions and Limitations

1. The product must be installed and operated in accordance with the instruction published by the Manufacturer **or Warranty will be void.**
2. The product must be installed according to all applicable federal, State and local codes or regulations **or Warranty will be void.**
3. Warranty is **void if all components** of the product or system are not original equipment supplied by the Manufacturer.
4. This product must be purchased from and installed by an authorized distributor or certified representative thereof **or the Warranty will be void.**
5. Malfunctions or failure resulting from misuse, abuse, negligence, alteration, accident, of lack of proper maintenance, or from lightning strikes, electrical power surges or interruption of electricity, shall not be considered defects under the Warranty.
6. This Warranty applies only to systems for the care of poultry and livestock. Other applications in industry or commerce are not covered by this Warranty.

The Manufacturer shall not be liable for any **Consequential or Special Damage** which any purchaser may suffer or claim to suffer as a result of any defect in the product. **"Consequential"** or **"Special Damages"** as used herein include, but are not limited to, lost or damaged products or goods, costs of transportation, lost sales, lost orders, lost income, increased overhead, labor and incidental costs and operational inefficiencies. THIS WARRANTY CONSTITUTES THE MANUFACTURER'S ENTIRE AND SOLE WARRANTY AND THE MANUFACTURER EXPRESSLY DISCLAIMS ANY AND ALL OTHER WARRANTIES, INCLUDING, BUT NOT LIMITED TO, EXPRESS AND IMPLIED WARRANTIES AS TO MERCHANTABILITY, FITNESS FOR PARTICULAR PURPOSES SOLD AND DESCRIPTION OR QUALITY OF THE PRODUCT FURNISHED HEREUNDER.

Agile Distributors are not authorized to modify or extend the terms and conditions of this Warranty in any manner or to offer or grant any other warranties for Agile products in addition to those terms expressly stated above. An officer of Agile must authorize any exceptions to this Warranty in writing. The Manufacturer reserves the right to change models and specifications at any time without notice or obligation to improve previous models.

Agile Mfg., Inc.
720 Industrial Park Road, Anderson, MO 64831 U.S.A.
Phone (417) 845-6065 Fax (417) 845-6069 agilemfg.net

Effective 3/04